

G-SERIES
**COMPACT TRACK
LOADERS**



JOHN DEERE

325G / 331G / 333G



**INTELLIGENCE
AT WORK**



WORKING HARD SO YOU CAN

WORK SMART

THE JOHN DEERE
"G-FORCE"

ART.



RELIABLE

+



PRODUCTIVE



YOUR INSPIRATION, OUR DEDICATION.

You run 'em, so why wouldn't we pick your brain about your expectations of a compact track loader (CTL)? As participants in our Customer Advocate Group, users like you stepped up and helped point the way for the G-Series. Challenged and inspired by your thoughts and ideas, we went to work on Generation Next. We added more power under the hood and increased lift height, reach, stability, and breakout force. We paid attention to the little things that are a big deal to our customers, like optional heated seat, side lighting, and rearview camera — for more productivity and uptime, at a lower daily operating cost. And now our 333G SmartGrade™ is the first compact machine to feature fully integrated 3D grade-control technology.

HEAD-TURNING PERFORMANCE

SEE WHAT YOU CAN DO.

You're going to like what you see in these latest "Gs". They deliver performance that'll really grab your attention — as well as your share of the work.

Grade it easy

Standard DozerMode makes manual grading easier and more intuitive than with traditional dozer-blade attachments, helping you grade like a pro, for smoother passes in less time.

Beast mode

Extreme pushing power and bucket breakout forces deliver the tractive effort and leverage to carve out clay, power through piles, and handle heavy loads.

Speedsters

Standard on the 331G and 333G (optional on the 325G), two-speed drivetrain delivers travel speeds over eight mph, for quick work cycles.

Fewer pit stops

Fluid-efficient diesels and large tanks enable daylong operation, letting you do more between fill intervals.

Rock-solid stability

Longer track frames and optimized roller spacing on the 331G and 333G improve balance and stability, to enhance agility and operator comfort.

EH boom performance package

Shorten cycle times and speed production in repetitive boom applications with the optional electrohydraulic (EH) boom performance package available on 331G and 333G models.

Hydraulic boost

Increased auxiliary hydraulic flow and power enable G-Series CTLs to make the most of an even broader range of attachments.



2-SPEED DRIVETRAIN

STANDARD ON THE 331G AND 333G,
OPTIONAL ON THE 325G



STANDOUT FEATURE

TALL ORDER.





DO MORE WITH ONE ***REACH HIGHER WITH LESS EFFORT.***

The refined vertical-lift loader design of these compact models rises higher and reaches farther than previous models, for quicker and easier loading. G-Series CTLs serve up substantially greater boom breakout force, so you accomplish more with just one CTL. They also work comfortably in tight quarters, and they're easy to trailer. Now, who says you can't always get what you want?

Power lifter

Increased rated operating capacities up to 3,700 pounds give these machines the muscle you need to tote heavy loads.

Carry more, spill less

Boom design keeps the load close to the machine for better stability. Low center of gravity, up to 35-degree bucket rollback, and optional ride control and self-leveling also help keep buckets heaped and forks fully loaded.

Dig in

Breakout force has been increased substantially over our previous models, to make lifting heavy loads easier. Helps heap the bucket and keep big loads coming, too.

Load warrior

Height to hinge pin up to 11 feet enables these CTLs to easily load tandem-axle dump trucks, feed mixers, and fill hoppers. You'll also appreciate the additional reach to truck-bed height when handling pallets of pavers or other heavy materials.

Grade it easy

The new 333G SmartGrade includes Deere's patent-pending DozerMode. A quick push of a button on the sealed-switch module switches to the electro-hydraulic (EH) control pattern for the CTL to function like a crawler dozer, enabling intuitive operation.



SWITCH TO DOZERMODE
FOR INTUITIVE CRAWLER
DOZER OPERATION

ROOM WITH A VIEW

EFFICIENT OPERATION THAT'S EASY TO SEE.

Spacious, comfortable cab is tightly sealed to keep out noise and dust. Available options include a four-season cab, Bluetooth® radio, and a heated seat.

Your controls, your way

Choose from four different control styles and performance features:

- Standard equipment: Electrohydraulic (EH) ISO-pattern joystick controls on the 325G, 331G, and 333G
- Optional ISO-H switchable joystick controls and EH joystick performance package*
- Optional EH 4-way switchable controls, including EH foot control, ISO joystick control, H-pattern joystick control, and ISO and foot controls on the 331G and 333G
- Optional ISO controls with programmable detents with the EH joystick performance package* and the EH boom performance package on the 331G and 333G†

**EH joystick performance package features switchable accelerator/decelerator, selectable propel speeds, creep control, boom- and bucket-speed settings, and 12-volt 3- and 14-pin attachment-control harness with dash-mounted 4th-function rocker switch.*

†EH boom performance package features include EH bucket self-level up and down, return to dig, return to carry, and boom-height kick-out.

Four-season comfort

Add a heated air-suspension seat to the heated and air-conditioned pressurized cab to enhance comfort no matter the weather.

Get good grades

Available on the 330G and 332G, optional onboard grade-indication provides a real-time readout of cross-slope (roll of the machine) and mainfall slope (pitch of the machine) on the in-cab monitor:

- Reference **absolute value**, or machine relationship to an absolute flat plane, to easily grade a flat pad.
- Access **relative value**, or machine relationship to the existing grade, to make a steeper existing grade.

Heads-up operation

Easy-to-read LCD monitor provides a wealth of machine info and control — including vital operating conditions and advanced diagnostics.

Lighten up

Excellent all-around visibility has been further enhanced with customer-inspired LED side-lighting and rearview-camera options.

Push-button convenience

Optional sealed-switch module controls amenities such as keyless start and anti-theft settings, plus fingertip activation of numerous machine functions including optional ride control and self-leveling.

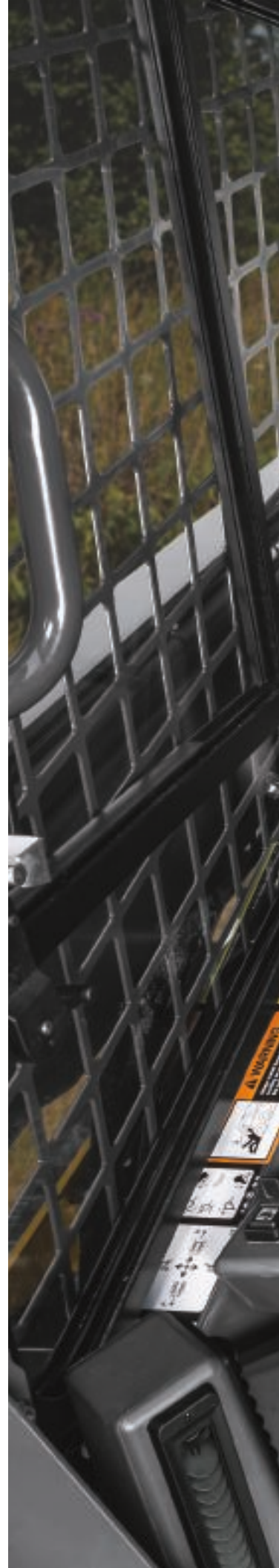



OPTIONAL
4-SEASON CAB
FOR ALL-WEATHER PRODUCTIVITY



DEERE

331C



TOUGH ENOUGH

UPTIME YOU CAN BANK ON.

Like all John Deere machines, the G-Series is loaded with features that help save time and money. When you know how they're built, you'll run a Deere CTL.



In-boom hydraulics

Auxiliary hydraulic lines and wiring are routed through the boom where they're protected from damage.

Smooth operator

Optional anti-vibration undercarriage system for the 333G* allows higher travel speeds over rough terrain with better material retention and lower operator fatigue. New bogie system enables smoother transitions over uneven surfaces.

Cool idea

Unique V-plenum (325G) and Tri-Cool (331G and 333G) designs employ large coolers for impressive performance in severe, high-load conditions.

Handy component access

These CTLs share components such as engines with our skid steers and compact excavators, which streamlines the filters and fluids you need on hand when you run a Deere fleet.

**Only for zig-zag-bar tracks; not compatible with SmartGrade or SmartGrade with Slope Control.*



TRI-COOL™
SYSTEM DESIGN
(331G AND 333G ONLY)



WORK OUR CONNECTIONS.

BE MORE THINGS TO MORE PEOPLE.

If you're looking for a way to help build your business, John Deere attachments are a great place to start. With more than 100 attachments, these specialized and general-purpose additions enable you to broaden your abilities, work smarter, and accomplish even more.



Bucket choices abound

Choose from rock, multipurpose, construction, utility, tooth, grading-heel, and rollout buckets in varying widths and capacities. Extreme-duty 90-inch tooth, serrated, or smooth-edge bucket lets you make the most of every cycle.



Clear it out

A rugged root rake, rotary cutter, or mulching head can help tackle tough land-clearing tasks.

Snow business

Equipped with optional zig-zag-style tracks and a snow blade, blower, or pusher, G-Series machines make quick work of cleaning up whatever winter drops your way.

Streetwise

Perfect for concrete or asphalt flatwork, our angle brooms, vibratory rollers, cold planers, hydraulic hammers, and a wide range of buckets let you hit the ground running.

Landscape tools

Landscape and nursery options include nursery forks, rotary tillers, planetary augers, pallet forks, power rakes, dozer blades, and roller levels, to list just a few.

Farm hands

For handling hay, cleaning pens, rebedding stalls, or numerous other agricultural chores, we've got the bale huggers, bale spears, grapples, material/manure scrapers, forks, and buckets to get it done.

Get attached

Universal Quik-Tatch™ enables you to go from bucket, to forks, to whatever, in just seconds, to accomplish more with one machine. Generous standard and optional high-flow auxiliary hydraulics let you effortlessly run powered attachments such as planetary augers, hydraulic hammers, and trenchers.

WE SWEAT THE DETAILS

SO YOU DON'T HAVE TO.

Simplified checks

Color-coded handles and caps on conveniently positioned dipstick and filler necks simplify checks and additions. Handy access eases refills of both fuel and diesel exhaust fluid (DEF)* tanks. See-through reservoirs and sight gauges reveal hydraulic oil and windshield washer fluid levels at a glance.

**331G and 333G only; DEF fluid not required on the 325G.*

Full-tilt service

Tilt the hood up for convenient access from ground level to dipstick, fuel- and fluid-filler necks, and filters. For wide-open drivetrain access, the operator's station swings up and out of the way in less than five minutes.

Generous power

Turbocharged diesels meet rigid emission standards, run smooth, and pack plenty of power and torque.

Have it both ways

John Deere-designed and -built six-way SG96 Dozer Blade is tough enough to cut grade, but it can also smoothly and precisely spread or fine-grade materials where they need to go. EZGrade augments the control system to stabilize the blade and help enable smooth grading operation. Heavy-duty components deliver reliable uptime and long-term durability.



Easy interior maintenance

If you're a neat freak or run a rental yard, you'll appreciate the convenient cab-footwell floor access that helps speed cleanout. Cab side windows also remove easily for cleaning.

Convenient cooler cleanout

Hinged hood and easy-to-remove side shields yield wide-open access to coolers, simplifying core cleanout. Fan option can be set to automatically reverse to clear core-clogging buildup.

JDLink™ machine monitoring

Optional JDLink provides machine data and health alerts to help you decrease costly downtime.





325G SPECIFICATIONS

While general information, pictures, and descriptions are provided, some illustrations and text may include product options and accessories NOT AVAILABLE in all regions, and in some countries products and accessories may require modifications or additions to ensure compliance with the local regulations of those countries.

Engine		325G
Manufacturer and Model	Yanmar 4TNV98CT	
Non-Road Emission Standard	EPA Final Tier 4/EU Stage IV	
Cylinders	4	
Gross Rated Power (ISO 14396)	54.8 kW (74 hp) at 2,500 rpm	
Net Power (SAE J1349 / ISO 9249)	52.5 kW (70 hp) at 2,500 rpm	
Peak Torque	280 Nm (207 lb.-ft.) at 1,800 rpm	
Displacement	3.3 L (203 cu. in.)	
Rated Engine Speed	2,500 rpm	
Torque Rise	34% at 1,800 rpm	
Aspiration	Turbocharged	
Air Cleaner	Dry dual element	
Cooling		
Fan Type	Variable-speed hydraulic drive standard / reversing fan drive optional	
Powertrain		
Pump	Axial-piston hydrostatic	
Controls	Electrohydraulic	
Travel Speeds		
Single Speed, Standard	9.3 km/h (5.8 mph)	
2 Speed, Optional		
Low	8.4 km/h (5.2 mph)	
High	13.2 km/h (8.2 mph)	
Brake	Integral, automatic, spring-applied, hydraulically released wet-disc brake	
Undercarriage		
Rubber Tracks	New-Generation smooth-ride long-life rubber with steel inserts	
Track Width		
Standard	320 mm (12.6 in.)	
Optional	400 mm (15.8 in.)	
Ground Pressure		
Standard 320-mm (12.6 in.) Track	39.3 kPa (5.7 psi)	
Optional 400-mm (15.8 in.) Track	32.4 kPa (4.7 psi)	
Track Rollers (per side)	4 triple-flange smooth-ride all-steel rollers	
Track Idlers (per side)	2 double-flange smooth-ride all-steel rollers	
Bearings/Seals (rollers/idlers)	Heavy-duty journal bearings and metal face seals	
Tractive Effort	3859 kgf (8,500 lbf)	
Hydraulics		
Pump Flow		
Standard	78 L/m (21 gpm)	
Total With High-Flow Option	120 L/m (32 gpm)	
System Pressure at Couplers	23 787 kPa (3,450 psi)	
Hydraulic Horsepower Flow (calculated)		
Standard	31.1 kW (41.7 hp)	
High	47.4 kW (63.6 hp)	

325G SPECIFICATIONS



While general information, pictures, and descriptions are provided, some illustrations and text may include product options and accessories NOT AVAILABLE in all regions, and in some countries products and accessories may require modifications or additions to ensure compliance with the local regulations of those countries.

Cylinders	325G
Type	John Deere heat-treated, chrome-plated polished cylinder rods, hardened steel (replaceable bushings) pivot pins
Electrical	
Voltage	12 volt
Battery Capacity	750 CCA standard / 925 CCA optional
Alternator Rating	75 amp
Lights	Halogen, 2 front and 1 rear
Operator's Station	
ROPS (ISO 3471) / FOPS (ISO 3449) structure with quick-pivot standard	
Serviceability	
Refill Capacity	
Fuel Tank	79 L (21 gal.)
Operating Weights	
With Standard 320-mm (12.6 in.) Track	4313 kg (9,500 lb.)
With Optional 400-mm (15.8 in.) Track	4381 kg (9,650 lb.)
Machine Dimensions	
A Length Without Bucket	2.85 m (112.3 in.) (9 ft. 4 in.)
B Length With Foundry Bucket	3.46 m (136.3 in.) (11 ft. 4 in.)
C Width Without Bucket	
With 320-mm (12.6 in.) Track	1.82 m (71.5 in.) (6 ft. 0 in.)
With 400-mm (15.8 in.) Track	1.90 m (74.7 in.) (6 ft. 3 in.)
D Height to Top of ROPS	2.06 m (81.1 in.) (6 ft. 9 in.)
E Height to Hinge Pin	3.20 m (126.1 in.) (10 ft. 6 in.)
F Dump Height With Foundry Bucket	2.59 m (102.1 in.) (8 ft. 6 in.)
G Dump Reach	
With Foundry Bucket	0.75 m (29.7 in.)
With Construction Bucket With Edge	0.94 m (37 in.) (3 ft. 1 in.)
H Ground Clearance	0.24 m (9.3 in.)
I Angle of Departure	30.5 deg.
J Front Turn Radius With Foundry Bucket	2.03 m (80 in.) (6 ft. 8 in.)
K Dump Angle (full lift height)	41 deg.
L Bucket Rollback (ground level)	34 deg.
Loader Performance	
Tipping Load	3360 kg (7,400 lb.)
SAE Rated Operating Capacity With Foundry Bucket	
At 35% Tipping Load	1176 kg (2,590 lb.)
At 50% Tipping Load	1680 kg (3,700 lb.)
Boom Breakout Force	
With Foundry Bucket	2384 kg (5,250 lb.)
With Heavy-Duty Construction Bucket	2157 kg (4,750 lb.)
Bucket Breakout Force	
With Foundry Bucket	3973 kg (8,750 lb.)
With Heavy-Duty Construction Bucket	2724 kg (6,000 lb.)

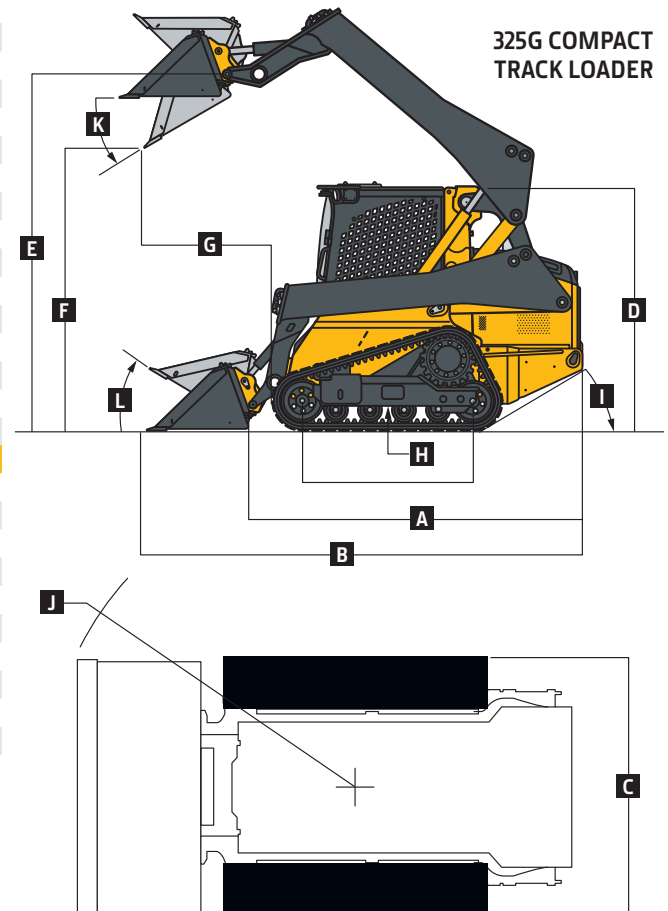



331G / 333G SPECIFICATIONS

While general information, pictures, and descriptions are provided, some illustrations and text may include product options and accessories NOT AVAILABLE in all regions, and in some countries products and accessories may require modifications or additions to ensure compliance with the local regulations of those countries.

Engine	331G	333G
Manufacturer and Model	Yanmar 4TNV94FHT	Yanmar 4TNV94FHT
Non-Road Emission Standards	EPA Final Tier 4/EU Stage IV	EPA Final Tier 4/EU Stage IV
Cylinders	4	4
Gross Rated Power (ISO 14396)	68.0 kW (91.2 hp) at 2,500 rpm	74.6 kW (100 hp) at 2,500 rpm
Net Peak Power (SAE J1349 / ISO 9249)	66.0 kW (88.5 hp) at 2,500 rpm	72.0 kW (96.6 hp) at 2,500 rpm
Peak Torque	382 Nm (281.8 ft.-lb.) at 1,700 rpm	395 Nm (291.3 ft.-lb.) at 1,700 rpm
Displacement	3.1 L (186.3 cu. in.)	3.1 L (186.3 cu. in.)
Rated Engine Speed	2,500 rpm	2,500 rpm
Torque Rise	47% at 1,700 rpm	39% at 1,700 rpm
Aspiration	Turbocharged, intercooled	Turbocharged, intercooled
Air Cleaner	Dry dual element	Dry dual element
Cooling	331G / 333G	
Fan Type	Variable-speed hydraulic drive standard / reversing fan drive optional	
Powertrain	331G	333G
Pump	Axial-piston hydrostatic	Axial-piston hydrostatic
Controls	Electrohydraulic	Electrohydraulic
Travel Speeds		
2 Speed, Low	8.5 km/h (5.3 mph)	8.5 km/h (5.3 mph)
2 Speed, High	12.6 km/h (7.8 mph)	12.6 km/h (7.8 mph)
Brakes	Integral, automatic, spring-applied, hydraulically released wet-disc brake	
Undercarriage	New-Generation smooth-ride long-life rubber with steel inserts	
Rubber Tracks	New-Generation smooth-ride long-life rubber with steel inserts	
Track Width		
Standard	400 mm (15.8 in.)	450 mm (17.7 in.)
Optional	450 mm (17.7 in.)	400 mm (15.8 in.)
Ground Pressure		
400-mm (15.8 in.) Track (standard on 331G / optional on 333G)	38.1 kPa (5.5 psi)	38.4 kPa (5.6 psi)
450-mm (17.7 in.) Track (optional on 331G / standard on 333G)	33.9 kPa (4.9 psi)	34.1 kPa (5.0 psi)
Track Rollers (per side)	5 triple-flange smooth-ride all-steel rollers	5 triple-flange smooth-ride all-steel rollers
Track Idlers (per side)	2 double-flange smooth-ride all-steel rollers	2 double-flange smooth-ride all-steel rollers
Bearings/Seals (rollers/idlers)	Heavy-duty journal bearings and metal face seals	Heavy-duty journal bearings and metal face seals
Tractive Effort	5221 kgf (11,500 lbf)	5221 kgf (11,500 lbf)
Hydraulics	331G / 333G	
Pump Flow		
Standard	80 L/m (23.5 gpm)	95 L/m (25.0 gpm)
Total With High-Flow Option	138 L/m (36.5 gpm)	156 L/m (41.1 gpm)
System Pressure at Couplers	23 787 kPa (3,450 psi)	23 787 kPa (3,450 psi)
Hydraulic Horsepower Flow (calculated)		
Standard	35 kW (47 hp)	38 kW (50 hp)
High	55 kW (74 hp)	62 kW (83 hp)
Cylinders	331G / 333G	
Type	John Deere heat-treated, chrome-plated, polished cylinder rods, hardened steel (replaceable bushings) pivot pins	
Electrical	331G / 333G	
Voltage	12 volt	
Battery Capacity	925 CCA	
Alternator Rating	90 amp	
Lights	Halogen: 2 front and 1 rear standard / deluxe LED: 4 front and 1 rear optional	
Operator's Station	331G / 333G	
ROPS (ISO 3471) / FOPS (ISO 3449) structure with quick-pivot standard		
Serviceability	331G / 333G	
Refill Capacity	331G / 333G	
Fuel Tank	114 L (30 gal.)	
Operating Weights	331G	333G
With Standard 400-mm (15.8 in.) Track	5403 kg (11,900 lb.)	—
With Standard 450-mm (17.7 in.) Track (includes 3 sets of counterweights and dozer blade)	—	6356 kg (14,000 lb.)

331G / 333G SPECIFICATIONS



While general information, pictures, and descriptions are provided, some illustrations and text may include product options and accessories NOT AVAILABLE in all regions, and in some countries products and accessories may require modifications or additions to ensure compliance with the local regulations of those countries.

Machine Dimensions		331G / 333G	
A	Length Without Bucket	3.10 m (122 in.)	(10 ft. 2 in.)
B	Length With Foundry Bucket	3.71 m (146 in.)	(12 ft. 2 in.)
C	Width Without Bucket		
	With 400-mm (15.8 in.) Track	2.00 m (78.9 in.)	(6 ft. 7 in.)
	With 450-mm (17.7 in.) Track	2.05 m (80.7 in.)	(6 ft. 9 in.)
D	Height to Top of ROPS (including GNSS for 333G SmartGrade™)	2.30 m (90.5 in.)	(7 ft. 7 in.)
E	Height to Hinge Pin	3.35 m (132 in.)	(11 ft. 0 in.)
F	Dump Height With Foundry Bucket	2.69 m (106.1 in.)	(8 ft. 10 in.)
G	Dump Reach		
	With Foundry Bucket	0.71 m (28 in.)	
	With Construction Bucket (no edge)	0.88 m (34.6 in.)	
H	Ground Clearance	0.24 m (9.4 in.)	
I	Angle of Departure	31 deg.	
J	Front Turn Radius With Foundry Bucket	2.18 m (85.7 in.)	(7 ft. 2 in.)
K	Dump Angle (full lift height)	48 deg.	
L	Bucket Rollback (ground level)	35 deg.	

331G / 333G COMPACT TRACK LOADERS

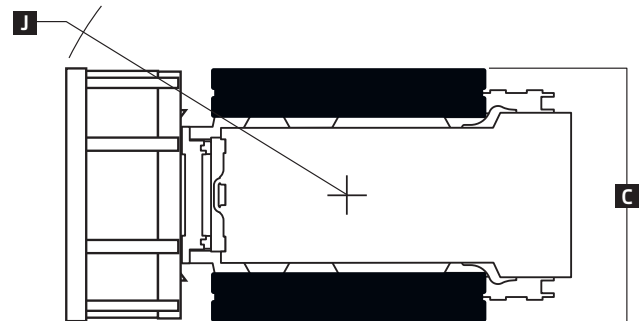
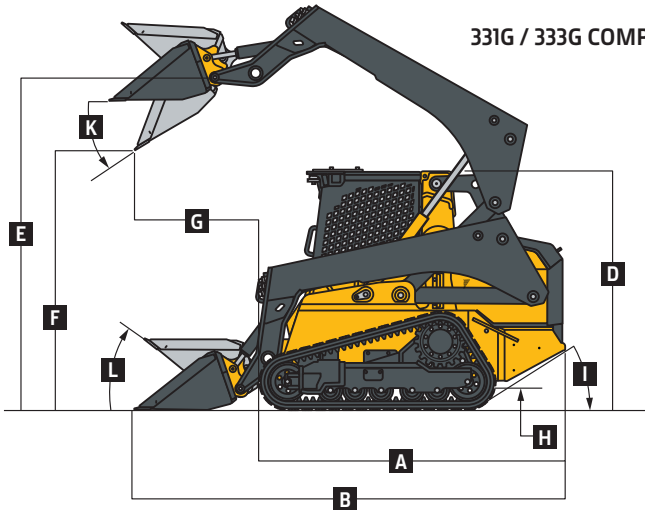

Loader Performance		331G	333G
	Tipping Load With Foundry Bucket	4021 kg (8,857 lb.)	5280 kg (11,630 lb.)
SAE Rated Operating Capacity			
	At 35% Tipping Load	1407 kg (3,100 lb.)	1848 kg (4,071 lb.)
	At 50% Tipping Load	2011 kg (4,429 lb.)	2640 kg (5,815 lb.)
Boom Breakout Force			
	With Foundry Bucket	2724 kg (6,000 lb.)	3746 kg (8,250 lb.)
	With Construction Bucket	2724 kg (6,000 lb.)	3519 kg (7,750 lb.)
Bucket Breakout Force			
	With Foundry Bucket	4688 kg (10,325 lb.)	6243 kg (13,750 lb.)
	With Heavy-Duty Construction Bucket	3450 kg (7,600 lb.)	4200 kg (9,250 lb.)

Dozer Dimensions		333G SMARTGRADE	
Blade Type		<i>Power-Angle-Tilt (PAT)</i>	
M	Blade Width	2440 mm (96 in.)	(8 ft. 0 in.)
N	Blade Height	740 mm (29 in.)	
	SAE Capacity	1.18 m ³ (1.54 cu. yd.)	
	Weight	640 kg (1,400 lb.)	
O	Blade Angle	±24 deg.	
P	Overall Width With Blade Angled	2258 mm (88 in.)	(7 ft. 4 in.)
Q	Blade Tilt	±8 deg.	
R Cut Reach			
	With 400-mm (15.8 in.) Narrow Track	15.3 mm (0.6 in.)	
	With 450-mm (17.7 in.) Wide Track	-22.2 mm (-0.8 in.)	
S Width Over Track			
	With 400-mm (15.8 in.) Narrow Track	2000 mm (78.9 in.)	(6 ft. 6.9 in.)
	With 450-mm (17.7 in.) Wide Track	2047 mm (80.7 in.)	(6 ft. 8.7 in.)
T Cast Reach			
	With 400-mm (15.8 in.) Narrow Track	246 mm (9.7 in.)	
	With 450-mm (17.7 in.) Wide Track	223.8 mm (8.8 in.)	
U Length With Dozer Blade Installed			
	With 400-mm (15.8 in.) Narrow Track	3940 m (155 in.)	(12 ft. 11 in.)
	With 450-mm (17.7 in.) Wide Track	3940 m (155 in.)	(12 ft. 11 in.)

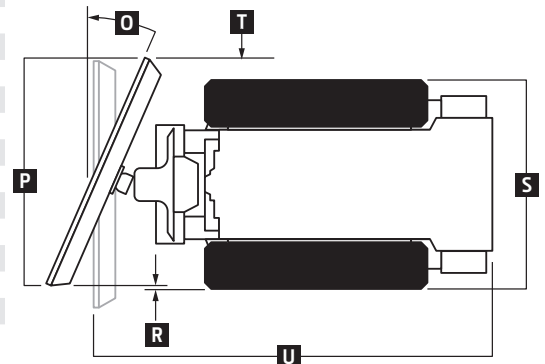
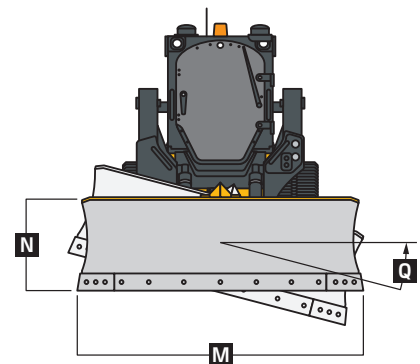

Additional equipment

Key: ● Standard ▲ Optional or special

See your John Deere dealer for further information.

325G	331G	333G	Engine
●	●	●	Meets EPA Final Tier 4/EU Stage IV emissions
▲			Meets EPA Interim Tier 4/EU Stage IIIA emissions
	▲	▲	Meets EPA Interim Tier 4/EU Stage IIIB emissions
●			Yanmar 4TNV98CT
▲			Yanmar 4TNV98T
	●	●	Yanmar 4TNV94FHT
	▲	▲	Yanmar 4TNV94CHT
●	●	●	Auto-idle
●	●	●	Automatic fan tensioner
●	●	●	Automatic preheat
●	●	●	Electronic injection system
▲	▲	▲	Engine air precleaner kit
●			Fuel tank, 79 L (21 gal.)
	●	●	Fuel tank, 114 L (30 gal.)
●	●	●	John Deere COOL-GARD™ II Extended-Life Engine Coolant
●	●	●	John Deere Plus-50™ 10w30 initial engine oil fill ⁵
●			4-cylinder 54.8 kW (74 gross hp)/52.5 kW (70 net hp), 3.3-L (203 cu. in.) displacement
	●		4-cylinder 68.0 kW (91.2 gross hp)/66.0 kW (88.5 net hp), 3.1-L (186.3 cu. in.) displacement
		●	4-cylinder 74.6 kW (100 gross hp)/72.0 kW (96.6 net hp), 3.1-L (186.3 cu. in.) displacement
●	●	●	5-micron primary fuel filter and water separator
▲	▲	▲	Cold-weather starting package
Cooling System			
●	●	●	Coolant surge tank
●	●	●	Variable-speed hydraulically driven fan cooling system
▲	▲	▲	Reversing fan drive
Powertrain			
●	●	●	High-torque heavy-duty planetary-reduction final drive
●	●	●	Automatic spring-applied hydraulically released wet-disc park brake
●	●	●	Wet-disc brakes
●			Transmission, single speed
▲	●	●	Transmission, 2 speed
Hydraulic System			
●	●	●	John Deere hydraulic cylinders with cushioned boom cylinders
●	●	●	John Deere heat-treated, chrome-plated cylinder rods with replaceable bushings
●	●	●	Connect-under-pressure auxiliary couplers
●	●	●	Quick-check hydraulic fluid-level sight glass
●	●	●	1,000-hour, 5-micron hydraulic filter
▲	▲	▲	High-flow hydraulics
●	●	●	Axial-piston hydrostatic pump

325G	331G	333G	Electrical
●	●	●	Automatic engine/hydraulic shutdown protection system
●	●	●	Auxiliary hydraulics operator-presence system
●	●	●	Courtesy lighting
●	●	●	Deluxe instrumentation EMU with: Operator-selectable monitoring – Hour meter, engine rpm, battery voltage, diagnostics, EMU configuration, engine coolant temperature, hydraulic oil temperature / LED warning indicators – Glow plug, seat switch, seat belt, door open, auxiliary hydraulics, park brake engaged, 2-speed engaged, stop, low engine oil pressure, engine coolant over-temperature, battery not charging, air filter restriction, and hydraulic filter restriction
▲	▲	▲	Deluxe LED lighting package with additional cab-integrated side lights (2)
●	●	●	Front and rear halogen work lights
●	●	●	Triple-interlock operator-presence control system
●			Backup alarm
●			Battery, 750 CCA
▲	●	●	Battery, 925 CCA
●	●	●	Horn
▲	▲	▲	Hazard warning lights
▲	▲	▲	Strobe light, amber
Operator's Station			
●	●	●	Deluxe cab headliner
●	●	●	Electrohydraulic (EH) ISO-pattern joystick controls
▲	▲	▲	ISO-H switchable joystick controls and EH joystick performance package*
	▲	▲	EH 4-way switchable controls include EH foot control, ISO joystick control, H-pattern joystick control, and ISO and foot controls
	▲	▲	ISO controls with programmable detents and EH boom performance package; ¹ also includes EH joystick performance package*
	▲	▲	Onboard grade indication: Grade-control option delivers onboard readout within LCD monitor that provides slope of blade (cross-slope direction) and mainfall (fore/aft direction) within ±0.5-percent accuracy
▲	●	●	Keyless-start sealed-switch module with integrated anti-theft system and operator memory preference settings
●	●	●	Electronic push-button auxiliary controls
●	●	●	Pull-down adjustable lap bar
●	●	●	Quick-pivot ROPS
●	●	●	Rear window
●	●	●	Removable top window
▲	▲	▲	Sliding/locking/removable glass side windows

325G	331G	333G	Operator's Station (continued)
●	●	●	ROPS/FOPS operator structure
▲	▲	▲	Glass cab enclosure
●	●	●	Seat belt, 51 mm (2 in.), retractable
▲	▲	▲	Shoulder belt, 51 mm (2 in.) or 76 mm (3 in.)
▲	▲	▲	Severe-duty cab door and wiper system
●	●	●	Water-shedding deluxe vinyl suspension seat
▲	▲	▲	Air-ride cloth, heated seat
▲	▲	▲	Air-ride vinyl seat
●	●	●	12-volt power port / Dome light / Cargo storage / Beverage holder
▲	▲	▲	Air conditioning with heater/defroster
▲	▲	▲	AM/FM radio with auxiliary input and Bluetooth® for audio streaming
▲	▲	▲	Floor mat with left footrest
●	●	●	Rearview mirror
▲	▲	▲	Rearview camera
Loader			
●	●	●	In-cab boom lockout to secure loader before exiting seat
●	●	●	Patented John Deere Quik-Tatch™ (no grease required)
▲	▲	▲	Power Quik-Tatch
●	●	●	Patented John Deere vertical-lift boom
▲	▲	▲	Hydraulic self-leveling on/off and ride control
Other			
		▲	SmartGrade™
●	●	●	Convenient front and rear tie-downs
●	●	●	Environmental drains for all fluid reservoirs
▲	▲	▲	Chrome exhaust stack
▲	▲	▲	Engine oil/hydraulic fluid-sampling kit
▲	▲	▲	Forestry protection packages
▲	▲	▲	Heavy-duty rear grille
▲	▲	▲	Rear counterweights (available in sets of 1, 2, or 3), 78 kg (172 lb.) (each set)
▲	▲	▲	Single-point lift kit
▲	▲	▲	SMV sign kit
		▲	Anti-vibration undercarriage system
●			Track, 320-mm (12.6 in.) wide
▲	●	▲	Track, 400-mm (15.8 in.) wide
	▲	●	Track, 450-mm (17.7 in.) wide
▲	▲	▲	JDLink™ wireless communication system (available in specific countries; see your dealer for details)

⁵500-hour engine oil-change intervals when John Deere Plus-50 oil and John Deere oil filter are used.

*EH joystick performance package features switchable accelerator/decelerator, selectable propel speeds, creep control, boom- and bucket-speed settings, and 12-volt 3- and 14-pin attachment-control harness with dash-mounted 4th-function rocker switch.

¹EH boom performance package features include EH bucket self-level up and down, return to dig, return to carry, and boom-height kick-out.

While general information, pictures, and descriptions are provided, some illustrations and text may include product options and accessories NOT AVAILABLE in all regions, and in some countries products and accessories may require modifications or additions to ensure compliance with the local regulations of those countries.

Net engine power is with standard equipment including air cleaner, exhaust system, alternator, and cooling fan, at standard conditions per SAE J1349 and DIN 6270B, using No. 2-D fuel at 35 API gravity. Gross power is without cooling fan. Specifications and design subject to change without notice. Wherever applicable, specifications are in accordance with SAE standards. Except where otherwise noted, these specifications are based on units with standard equipment, full fuel tanks, and 79-kg (175-lb.) operator.

